

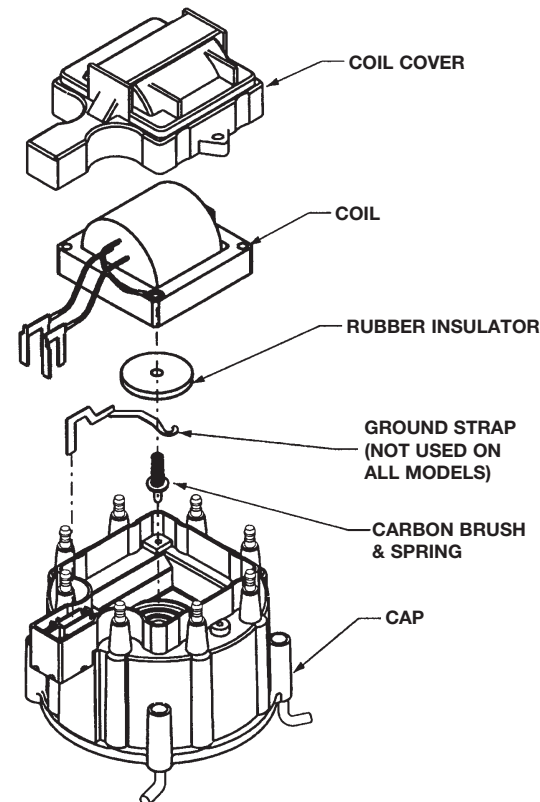

INSTALLATION INSTRUCTIONS

PART NO. 8200

TUNE UP KIT FOR GM HEI V8 DISTRIBUTORS



DISTRIBUTOR CAP COMPONENTS

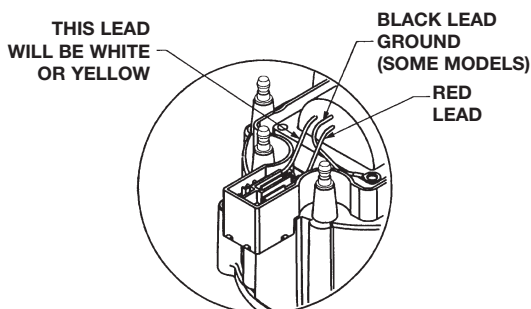

CAP REMOVAL

1. Disconnect the coil feed connector and module connectors from the distributor cap.
2. Remove the spark plug wire retainer, if so equipped.
3. Remove the coil cover. Retain the screws and cover.
4. Using needle nose pliers, lift the coil leads out of the distributor cap.

REPLACING CAP

1. Depress and twist to release the four distributor cap retaining screws. Remove the cap from the distributor.
2. Install the new carbon brush and spring in the cap. It is recommended to apply silicone grease to the rubber washer for a better seal, then place the washer into position in the cap.
3. Install coil making sure the leads are in position as indicated in the illustration.
4. Reinstall original coil mounting screws, coil cover, cover retaining screws, and distributor cap on distributor.
5. Reinstall spark plug wires and retaining rings (if applicable) then reconnect coil feed connector and module connectors to the distributor cap.

VACUUM ADVANCE

Insert ~~the supplied~~ 3/32" hex wrench in the vacuum canister nipple and rotate the adjusting screw counter-clockwise until it bottoms against its stop, then turn four complete turns clockwise. This is approximately 7" dist. (14" eng.) at approximately 12" vacuum. This is a starting point for the vacuum advance adjustment. If surging or pinging is noticed at cruise RPM, turn the adjustment counter-clockwise until condition is no longer noticed. If more advance is needed, turn adjustment clockwise.

CONTROL MODULE AND COIL HARNESS REPLACEMENT

1. Remove the cap and rotor for ease of installation
2. Remove the white and green magnetic pick up wires from the control module.
3. Next remove the screw holding the condenser down.
4. Remove the 2 screws holding the control module down. You can now lift the module and coil harness from the distributor.

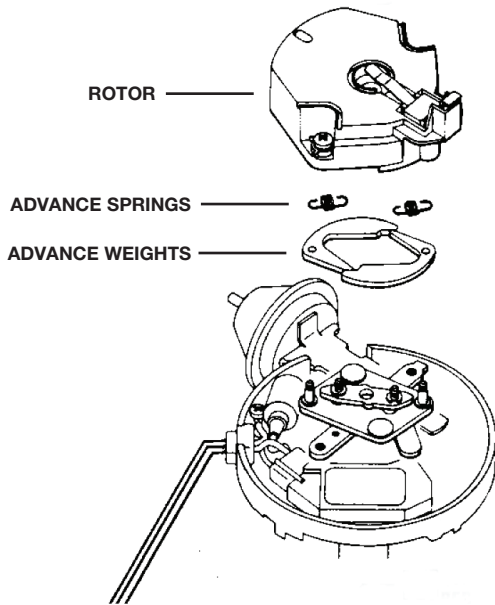

the timing to the stock setting. (Refer to an auto repair manual for stock setting.) Replace the vacuum line and readjust the idle to factory specifications or other value, as desired.

To eliminate advance until 10" of vacuum is reached, use Chevrolet P/N 1973511 Vacuum Pot Assembly to eliminate any vacuum advance while accelerating.

IMPORTANT: THIS PRODUCT MAY NOT BE ACCEPTABLE BY LAW IN SOME STATES.

FIGURE 1

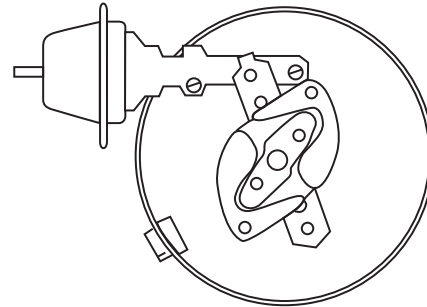

CLOCKWISE ROTATION

5. Use the supplied white heat transfer grease and moderately coat the bottom of the control module and the surface where the module sits in the distributor.
6. Before replacing the module attach the new coil harness and condenser assembly the module.
7. You can now place the control module, harness, and condenser back into the distributor.
8. Using the stock screws fasten the assembly and condenser back into place.
9. Reconnect the white and green magnetic pick up wires to the module.

NOTE: The module pins will have "W" marking for the white wire and a "G" for the green wire.

FIGURE 2

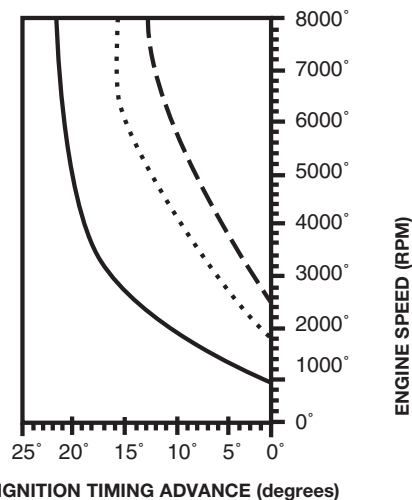

IGNITION TIMING ADVANCE (degrees)

— Black Springs
 ... Silver Springs
 - - Gold Springs

INSTALLATION INSTRUCTIONS FOR HEI ADVANCE CURVE KIT

1. Remove the distributor cap and rotor.
2. Remove the stock springs, "E" clips, weights, and center plate.
3. The new center plate is designed to operate in either clockwise or counter clockwise rotation distributors. It is important to install the plate and centrifugal weights as shown in Figure 1 for the clockwise rotation distributors. For counter clockwise rotation, turn over the center plate and centrifugal weights. Replace the "E" clips.
4. Before installing the centrifugal weights, select the bushing set, ~~from the two sets provided~~, that fits snugly on the weight pins. Press these bushings into the weights and install the assemblies into the distributor.
5. Using the graph as reference, Figure 2, select the springs which correspond to the curve desired.
6. With the springs in place, replace the distributor cap and rotor.
7. To set the timing, remove the vacuum line from the distributor. (Be sure to plug the vacuum line while making adjustments.) Set the idle at 750 rpm and

INSTALLATION OF THE BATTERY/TACHOMETER PIGTAIL HARNESS

This positive lock connector simply plugs into the HEI distributor in front of the coil connector. It has a tab on the inside so it can only be installed in one position. Once installed the pigtails are color coated for ease of installation. The red wire goes to a 12 volt key switched wire. The green wire goes to your stock or aftermarket tachometer signal wire.



ACCEL IS A TRADEMARK OF PRESTOLITE PERFORMANCE
 10601 MEMPHIS AVE. #12, CLEVELAND, OH 44144
 (216) 688-8300 FAX (216) 688-8301

FORM INST8200
 12/11
 Made and printed in China